

**DIECI**



**APOLLO**

**26.6**



**dieci.com**

## PERFORMANCE

Vehicle model	APOLLO 26.6
Maximum capacity	2600 kg (5732 lb)
Maximum lifting height	5,68 m (18,6 ft)
Maximum horizontal extension	3,2 m (10,5 ft)
Fork swiveling angle	129°
Pull-out force	7600 daN (17085 lbf)
Towing force	4400 daN (9892 lbf)
Maximum climb angle	40%
Unladen weight	5000 kg (11023 lb)
Max speed (referred to wheels with maximum permitted diameter)	30 km/h (18,6 mph)

## BOOM

Vehicle model	APOLLO 26.6
Lifting	7,8 s
Descent	4,1 s
Extension	6,1 s
Retraction	3,4 s
Forward swiveling	3,5 s
Reverse swiveling	2,2 s

## ENGINE

Vehicle model	APOLLO 26.6
Brand	Kubota
Nominal power	55 kW (74 HP)
@rpm	2600 rpm
Operation	4-stroke
Injection	Electronic, Common rail
Number and arrangement of cylinders	4, Vertical in line
Displacement	3331 cm <sup>3</sup> (203 in <sup>3</sup> )
Consumption	231 g/kWh (380 lb/Hp h)
@rpm	2600 rpm
Emission standard	Stage V/Tier 4f
Exhaust gas treatment	Catalyst + Particulate filter (DOC+DPF)
Cooling system	Liquid
Intake	Turbo compressor

## DIFFERENTIAL AXLES

Vehicle model	APOLLO 26.6
Type of axles	2 steering, with 4 epicycloidal reduction gears
Type of steering	4 wheels / transversal / 2 wheels
Front axle	Rigid
Rear axle	Swinging
Service braking	Oil bath on front axle
Parking braking	Negative actuation with electrical control

## HYDRAULIC SYSTEM

Vehicle model	APOLLO 26.6
Hydraulic pump type	Gear pump for power steering and movements
Hydraulic pump capacity	80 L/min (21,1 gal/min)
Max. operating pressure	23,0 MPa (3336 psi)
Distributor control	4 in 1 proportional Joystick

## REFUELING

Vehicle model	APOLLO 26.6
Hydraulic system (total)	70,0 L (18,49 gal)
Fuel tank	80,0 L (21,13 gal)

## TRANSMISSION

Vehicle model	APOLLO 26.6
Transmission type	Single speed Hydrostatic transmission with variable displacement pump
Hydraulic motor	Hydrostatic with continuous automatic adjustment
Reversal	Electro-Hydraulic
Inching	With hydraulic pedal for controlled forward movement

## TIRES

Vehicle model	APOLLO 26.6
Standard tires	12x16.5"
Optional tires	15.0/55-17" - 12.0/75-18" - 280/80 R20"

## DIMENSIONS

Vehicle model	APOLLO 26.6
A	270 mm (10,6 in)
B	985 mm (38,8 in)
C	2350 mm (92,5 in)
D	765 mm (30,1 in)
F	3535 mm (139,2 in)
G	4125 mm (162,4 in)
H	1950 mm (76,8 in)
I	860 mm (33,9 in)
L	1500 mm (59,1 in)
M	1850 mm (72,8 in)
P	1460 mm (57,5 in)
Q	3555 mm (140 in)
S	1433 mm (56,4 in)
T	200 mm (7,9 in)

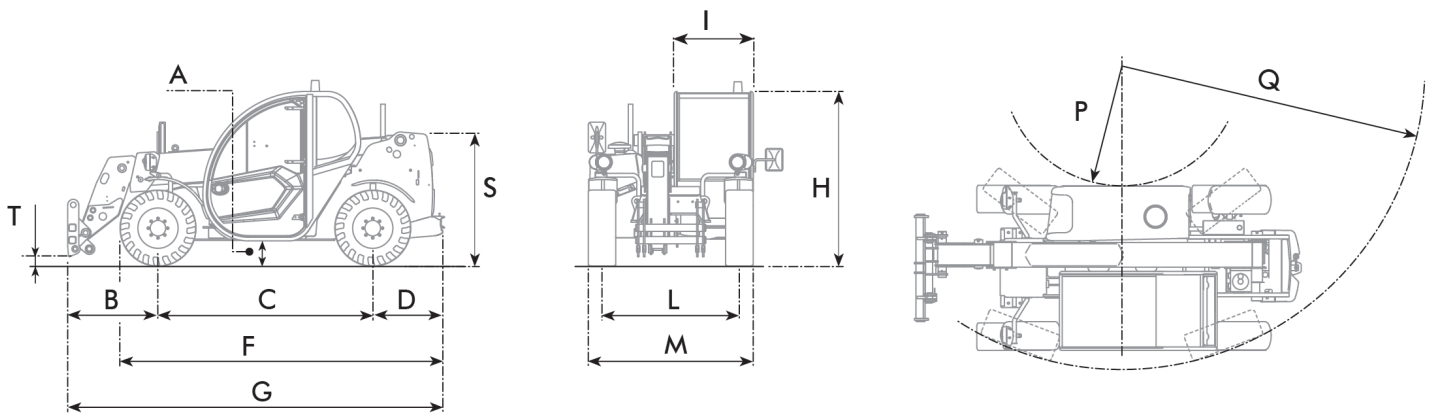

**MAX**  
2600 kg / 5732 lb

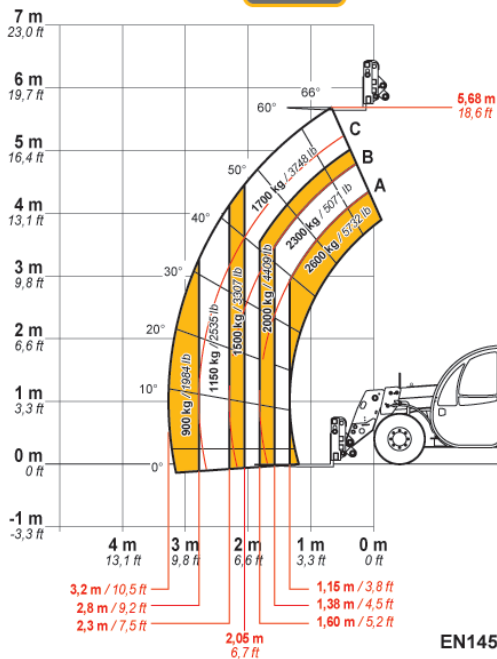

DOC10000822



EN1459 Annex-B

26.6



**Dieci Srl** - Via E. Majorana, 2-4 - 42027 - Montecchio Emilia (RE) ITALY

Tel. +39 0522 869611 - Fax +39 0522 869798 - E-mail: [info@dieci.com](mailto:info@dieci.com) - [www.dieci.com](http://www.dieci.com)

DOCCT0000010-EN-05